





SM36T



Automatic universal tyre-changer for truck, bus, agriculture and earth moving vehicles 14" - 46"

-  Smontagomme universale per pneumatici di autocarri, autobus, trattori e veicoli movimento terra, con cerchi a canale o ad anello elastico e per pneumatici con o senza camera ad aria. Mandrino idraulico a due velocità con 5 diverse posizioni di bloccaggio del cerchio, braccio porta utensile con ribaltamento e spostamento automatico. Unità di comando mobile equipaggiata con cavo anti schiacciamento e doppia spina militare.
-  Universal truck tyre changer designed for for truck, bus, agriculture and earth moving wheels, with grooved or split ring rims and for tyres tubeless or with inner tube. Two speed hydraulic chuck with 5 different rim locking positions automatic tilting/shifting tool holder arm and working tool with automatic rotation system. Mobile control unit with anti-crush cable and double military plug.
-  Démonte-pneus universel pour rous de camion, bus tracteurs et véhicules de chantier ou agricoles avec jantes à creux ou à cercle et avec ou sans chambre à air. Mandrin hydraulique à deux vitesses avec 5 différentes positions de blocage bras porte-util et bras porte-mandrino avec actionnement automatique, outil avec mécanisme automatique de rotation. Unité de commande mobile avec câble anti-écrasement et double prise militaire.
-  Universal Reifenmontiermaschine für Räder von Lkws, Bussen und Traktoren mit Tiefbett- und Sprengringfelgen, und mit und ohne Luftschlauch. Idraulisches Spannfutter mit zwei Drehgeschwindigkeiten und fünf verschiedenen Felgenspannstellungen automatisch verstellbarer und umklappbarer Werkzeugarm selbstdrehendes werkzeug. Mobiler Steuereinheit komplett mit schlagfestem Kabel und Doppelmilitärstecker.
-  Desmontadora universal para ruedas de camiones, autobuses, tractores y maquinarias de movimiento de tierra, con jantas de canal o de arillo, con y sin cámara de aire. Mandril hidráulico de dos velocidades con 5 diferentes posiciones de bloqueo de la llanta Brazo porta utensilio con inclinación y desplazamiento automático, utensilio con mecanismo automático de rotación. Unidad de control móvil equipada con cable anti aplastamiento y doble enchufe militar.

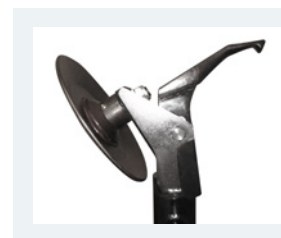

NEW

Per ruote da:	It handles wheels from:	Pour roues de:	Für Räder von:	14" - 46"
Peso max. ruota	Max. wheel weight	Poids maxi. roue	Maximalgewicht des Rads	1800 Kg
Larghezza max. ruota	Max. wheel width	Largeur maxi. roue	Radbreite	1.300 mm (53")
Diámetro max. ruota	Max. wheel diameter	Diam. maxi. roue	Max. Raddurchmesser	2.400 mm (98")
Motore centralina idraulica	Hydraulic unit motor	Moteur de la centrale hydraulique	Hydraulikaggregat-Motor	2.2 kW / 380V
Motore mandrino autocentrante	Chuck motor	Moteur du mandrin centreur	Spannfuttermotor	2.6 - 3.2 kW / 3 ph - 380 V
Pressione di servizio	Operating pressure	Pression de Service	Betriebsdruck	0 ÷ 130 bar
Forza stallonatore	Bead breaker force	Force décolleur	Abdrückkraft	2690 Kg
Peso lordo	Gross weight	Poids brut	Bruttogewicht	1025 Kg
Dimensioni imballo	Packing dimensions	Dimensions emballage	Kistenabmessungen	2080x1910x1100 mm

Accessori standard - Standard accessories - Accessoires en dotation - Standard Zubehörteile - Accesorios en dotación

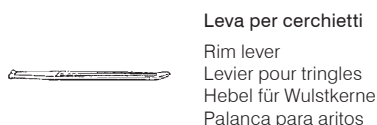

Leva per cerchietti
Rim lever
Lever pour tringles
Hebel für Wulstkerne
Palanca para aritos



Leva alzatalloni
Bead lifting lever
Lever décolle-talons
Wulstausdrückhebel
Palanca destalonadora



Pinza per cerchi
Rim pliers
Pince pour jantes
Felgenzange
Tenaza para llantas

Accessori opzionali - Optional accessories - Accessoires sur demande - Optionszubehörteile - Accesorios opcionales



Pinza per cerchi in lega
Pliers for alloy rims
Pince pour jantes en alliage
Zange für Leichtlegierunselgen
Tenaza para llantas en liga

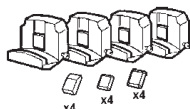

Serie di protezioni griffe per cerchi in lega
Jaw protections for alloy rims
Protections des griffes pour jantes en alliage
Satz von Klauenschütze für Leichtlegierunselgen
Juego de protecciones mordazas para llantas en liga



Set di 4 prolunghe fino a 56"
Set of 4 extensions up to 56"
Set de 4 rallonges jusqu'à 56"
Set mit 4 Verlängerungen bis 56"
Juego de 4 extensiones hasta 56"

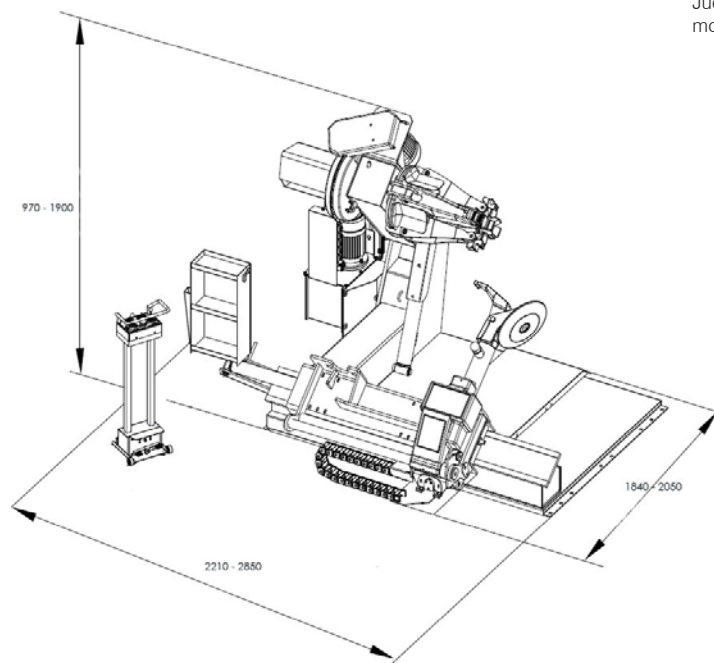

HEAVY DUTY BRONZE BEARINGS

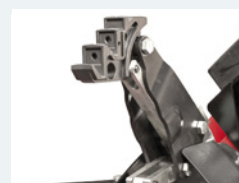

SPECIAL JAWS FOR AGRICULTURE



CEMB S.p.A.
Via Risorgimento, 9
23826 Mandello del Lario (LC) Italy
www.cemb.com

Garage equipment division
CEMB - ITALY
Plant and Training Center
phone +39 0341 706369
fax +39 0341 700725
garage@cemb.com

All the data and features mentioned in this catalogue are purely for information and do not constitute any commitment on the part of our company, which reserves the right to make any and all alterations it may consider suitable without notice.