

SM 630



AUTOMATIC
TYRE CHANGER

AUTOMATISCHES
REIFENMONTIERGERÄT



CEMB

SM 630



- Automatic tyre changer with **rear tilting post** and simultaneous vertical rod and horizontal arm pneumatic locking system, vertical arm with spring return.
- Automatisches Reifenmontiergerät mit **nach hinten kippbarer Montiersäule**, pneumatischem Simultanblockiersystem des vertikalen Werkzeugarms und des horizontalen Arms, Federrückzug des vertikalen Werkzeugarms.



- Vertical post equipped with **conic bushes** and play recovery systems which allow eliminating post flexure.
- Montiersäule mit **konischen Buchsen** und System, mit dem das Spiel abgefangen und Biegungen an der Säule verhindert werden.

- Self-centring plate with **10-24" locking capacity**, double rotation and two speeds.
- Plato autocentrante con capacidad de bloqueo de 10 – 24", doble sentido de rotación y doble velocidad.

- Body with **extractable pedal unit** to facilitate technical service, robust **reduction unit**, standard CE-certified inflation pressure limiter with provision for gun connection.
- Gehäuse mit **ausziehbarer Fußpedalleiste** für erleichterten Service, robustes Untersetzungsgetriebe, serienmäßiger, EU-genormter Befüllungsdruckminderer, der bereits für den Anschluss an die Druckluftpistole gerüstet ist.



Automatic tyre changer ideal for use in repair shops and tyre shops. Designed to operate on car and light commercial vehicle wheels and on motorcycle wheels with the appropriate accessories.

Automatisches reifenmontiergerät, ideal für werkstätten und reifenhändler, konzipiert für die bearbeitung von pkw- und llkw-rädern und, mit passendem zubehör, von motorradrädern.



- Bead breaker with **double-acting cylinder**, robust arm and **articulated blade**.
- Wulstabdrücker mit Doppelleffekt-Zylinder, robustem Arm und Gelenkschaufel.



OPTION OPTIONS

- Provision for mounting the **HP2 side presser** (optional) that allows easily carrying out all the mounting and dismounting operations of Run-flat and UHP tyres.
- Prädisponiert für die Montage des **seitlichen Pressarms HP2** (optional), der alle Montage- und Demontagearbeiten von Reifen des Typs Run-Flat und UHP erleichtert.



STANDARD ACCESSORIES - STANDARD ZUBEHÖRTEILE

The machine is supplied standard with a complete set of plastic guards to operate correctly on alloy rims (mounting head, bead breaker blade, bead lifter lever and self-centring plate jaw).

Zur korrekten Bearbeitung von Leichtmetallfelgen ist die Maschine serienmäßig mit einem kompletten Kunststoffschutz-Set ausgestattet (Kopfteil, Abpressschaufel, Montiereisen und Spannklauen des Selbstzentrierisches).



STANDARD FEATURES - TECHNISCHE ANGABEN

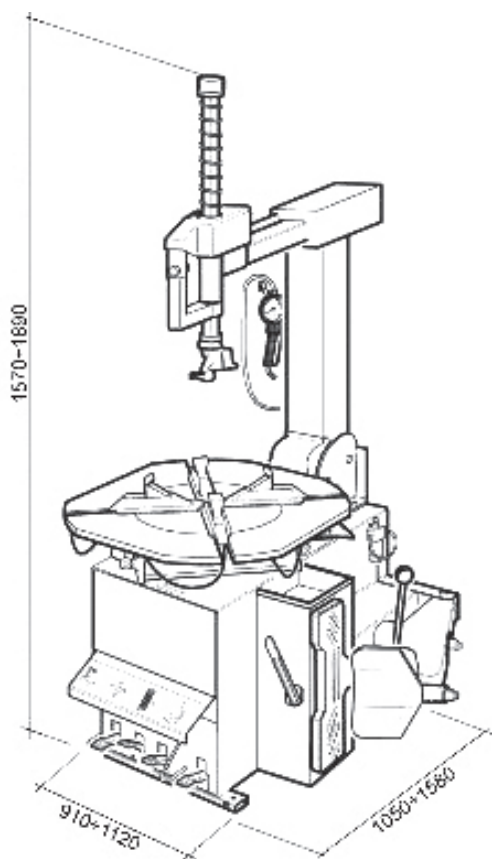

Clamping capacity	10 - 24"
External clamping	10 - 22"
Internal clamping	12 - 24"
Max wheel diameter	1000 mm (39.5")
Max wheel width	315 mm (12")
Bead breaker force	3080 Kgf (6790 lbf)
Turntable speed	6-12 rpm (8 rpm 1sp)
3-Phase motor	0.8 kW (1.07 Hp)
1-Phase motor	1.1 kW (1.47 Hp)
Operating pressure	8 - 10 bar (116 - 145 psi)
Noise level	< 70 ± 3 dB (A)
Net weight	220 Kg (485 lbs)
Gross weight	230 Kg (507 lbs)
Packing dimensions	760 x 975 x 950 mm

Spannbereich	10 - 24"
Einspannen aussen	10 - 22"
Einspannen innen	12 - 24"
Maximaler raddurchmesser	1000 mm (39.5")
Maximale radbreite	315 mm (12")
Abdrückkraft	3080 Kgf (6790 lbf)
Drehgeschwindigkeit	6-12 rpm (8 rpm 1sp)
Dreiphasenmotor	0.8 kW (1.07 Hp)
Einphasenmotor	1.1 kW (1.47 Hp)
Betriebsdruck	8 - 10 bar (116 - 145 psi)
Sonore geräuschpegel	< 70 ± 3 dB (A)
Nettogewicht	220 Kg (485 lbs)
Bruttogewicht	230 Kg (507 lbs)
Kistenabmessungen	760 x 975 x 950 mm

OPTIONAL ACCESSORIES - OPTIONSZUBEHÖRTEILE



HP2 - 93Y005000
x 1



SMA - 93Y005101
x 1



KCR - 93Y005050
x 1



TM - 93Y005053
x 1



SB - 93Y005210
x 1

For more information see the complete brochure - Zu weiteren Informationen siehe unsere ausführliche Broschüre



CEMB S.p.A.
Via Risorgimento, 9
23826 Mandello del Lario (LC) Italy
www.cemb.com

 **Garage equipment division**
CEMB - ITALY
Plant and Training Center
phone +39 0341 706369
fax +39 0341 700725
garage@cemb.com

CEMB USA - BL Systems Inc.
2873 Ramsey Road
Gainesville, GA 30501 - USA
Phone +001 678 717 1050
Fax +001 678 717 1056
sales@cemb-usa.com

All the data and features mentioned in this catalogue are purely for information and do not constitute any commitment on the part of our company, which reserves the right to make any and all alterations it may consider suitable without notice.